

POWERink
Air systems



PORTABLE AIR COMPRESSOR

DRIVEN BY DIESEL ENGINE

PORTABLE Air Compressor

AIR COMPRESSOR DRIVEN BY DIESEL ENGINE

OVERVIEW

POWERLINK air compressors are widely used in such industries as mining, water conservation, shipbuilding, city construction, energy resources and military, and are characterized by high efficiency, safety and stability, whilst remaining environmentally friendly.

POWERLINK air compressors have a power range of 10.8~297KW, displacement range to 30m³/min, and highest discharge pressure of 30Bar. Classified by two series, AR series and AS series; they are structurally divided into three types: Spirit, Eagle, Rhino. The compressors are driven by famous engines, such as KUBOTA, PERKINS, CATERPILLAR, CUMMINS and POWERLINK.

BENEFITS

STRONG POWER, STABLE PERFORMANCE, HIGH ECONOMICAL EFFICIENCY AND ENVIRONMENTAL PROTECTION



Main Parts

- ☑ Engine: high-efficiency and energy saving, stable, reliable, durable and with adequate reserve power; world-renowned KUBOTA, PERKINS, CATERPILLAR, CUMMINS and POWERLINK engines are in accordance with European II emission standards; and the engines worldwide after-sales service systems.



- ☑ The principal machine adopts a twin-screw rotor and is directly connected with the diesel engine by highly flexible coupling. The computer simulates the analysis of torsional vibration, and there is no overdrive gear in the middle which enables it to output more air with less energy consumption; characterized by high reliability, a longer service life and low maintenance costs.
- ☑ The air-oil separator filter adopts folding wave shaping technology, ensuring the largest possible filtering area with the same size. A spiral clash separation structure is adopted, and extension oil flow track is installed in the barrel for the purpose of ensuring below a 2PPM air-oil separation rate; all these guarantee the quality of discharge.



Intake System

- ☑ The device is equipped with a two-stage air filtration system with safety filter, which enables the total efficiency to reach 99.98% and ensures the air compressor is not be infringed by dust and dirty particles. When the filter needs to be replaced, the damping displayer will warn you timely. A pre-filter can be equipped under harsher and more dusty environments for extending the maintenance time of the air filter and service life of the engine.
- ☑ The intake system of the compressor adopts a butterfly valve mechanism and has a switching quantities adjustment function as well as a continuous adjustment function. The scope of stepless adjustment can reach 0-100% for air path control, which improves fuel economic efficiency under the condition that working pressure stability is guaranteed.



Cooling System

- ☑ High-performance fin type structure is designed with a high-temperature resistance ability, which can run for a long time under extreme cold or hot temperature from -20 °C to 50 °C; a safety protection cover is equipped.

Mobile System

- ☑ Service braking and parking braking systems ensure safety and reliability.
- ☑ Max running speed of road standard can reach 80km/h, for off-road standard, the running speed is less than 20km/h.
- ☑ Height-adjustable goose neck design is equipped with rotatable outrigger whose height can be also easily adjusted, which is applicable to field works under various conditions.

Shock Absorption System

- ☑ Vibration isolators are fitted between the engine, compressor and base frame, which can effectively reduce vibration and ensure stable running.
- ☑ Radiator adopts integrated shock absorption structure, which can effectively eliminate shear force, ensure effective buffering during moving, and prevent water leakage.
- ☑ All air, oil, water paths, and electrical wiring are aligned neatly and fixed to the machine, which will prevent malfunctioning during operations and movements.
- ☑ All the movable parts are effectively fixed to reduce vibration.



ENERGY-SAVING ENVIRONMENTAL PROTECTION

Energy-saving & Environmental-friendly Design

- ☑ Through mandatory air transmission, volume flow is not affected by discharge pressure, which can ensure high efficiency within the wide speed range.
- ☑ Diesel engine accelerator is automatically adjusted in line with the size of air consumption. The working pressure can be set quickly without wasting any diesel.
- ☑ Various series products can be customized in accordance with customer's requirements of air displacement and discharge pressure.
- ☑ Small size and light weight reduce logistics costs.

Low Noise

- ☑ The POWERLINK super soundproof structure is utilized in this design. The resistance integrated silencer structure can effectively reduce all noises in the middle and high frequency bands, which ensures quiet running of machine without affecting daily life.
- ☑ The internal wall of the machine adopts a new, special flame-retardant silencer cotton, specialized sealed rubber is used around the door, which can greatly absorb and cut off the noise and heat discharged by the machine during working.
- ☑ Advanced noise reduction design is integrated into many parts, such as air inlets/outlets and the unit's doors, effectively reducing noise output.



EXCELLENT SAFETY PERFORMANCE

Information Security

- ☑ Monitoring system is equipped to monitor the operational parameters in real time
- ☑ Multiple data display, monitor, warning and shutdown functions.

Operational Safety

- ☑ The radiator and high-speed rotating parts are equipped with protection covers; the heat pipe is protected by high-temperature cloth for avoiding injury caused by direct contact between people and machine.
- ☑ Radiator is equipped with a low water level protection function, water injection observation window and recovery tank.
- ☑ The machine is equipped with a battery isolator switch, which can prevent sudden starting up of the unit during maintenance.
- ☑ Air-oil separator and air filter are equipped with alarm indicators for periodic maintenance.

Advanced Waterproof and Dustproof Design

- ☑ The rainproof and dustproof design adopted by the control cabinet, each access door and assembly board is able to prevent rain and dust from entering, which can greatly improve protection class.



AIR COMPRESSOR

DRIVEN BY DIESEL ENGINE

EASY OPERATION

Personalized Design

- ☑ With reliable automatic functions, operators don't have to go through long term professional training, and unattended operation can be achieved.
- ☑ Control system adopts digital technology with microprocessor as core; control switch and indicating instrument are integrated at the same panel, which can facilitate real-time monitoring of operator.
- ☑ Starting up and fault automatic alarm device.
- ☑ Multiple languages are optional.
- ☑ Emergency stop button provides a more convenient operation method when the machine is in the state of emergency or overhauling.
- ☑ One-button start, clear operational parameters, personalized operating system, intelligent control, multiple warning and shutdown protection functions.
- ☑ Convenient refueling water device, the fuel tank is equipped with fuel level gauge and electronic fuel level sensor, facilitating monitoring fuel level while fuel-injection and low fuel level warning during the machine operation, which ensures the machine's continual operation.
- ☑ Fuel tank with large capacity ensures at least 8 hours or above running of the unit with full load.
- ☑ The inlet pipe is equipped with a fuel check valve and electronic fuel pump to ensure the start and load capacities of the machine, emptying device with a certain height ensures the smooth fuel-injection when the unit moves.
- ☑ Battery isolator switch, fuel pump, fuel gauge, folder, together with control cabinet are located on the same side to facilitate operation.
- ☑ All external parts of unit and internal parts are labelled, which effectively offers safety protection instructions and facilitates operation.





Easy Maintenance

- ☑ The machine adopts a twin screw rotor, less parts and quick-wear parts, which enable the machine to run stably with long service life; POWERLINK high-quality synthetic lubricating oil can be used to ensure the long life of the machine.
- ☑ Easily-replaced air-oil separator, double air filter and optional pre-filtering system can effectively filtrate impurities in the air to protect the engine. Hence, the machine is suitable for using in harsh and dusty environments, such as mine, outdoor works.
- ☑ Gull-wing wide open door structure designed on the basis of ergonomics, together with shutter which can be removed from front and rear, ensure you the best angle and operational space during maintenance, all the daily maintenance works can be conducted at both sides of the equipment.
- ☑ Integrated drain outlet installed at the chassis of unit is convenient for routine maintenance.
- ☑ The larger type air compressors are equipped with ladders, which are convenient for inspection, watering and machine lifting.



Easy Transportation

- ☑ The chassis is equipped with dragging and pulling functional parts, which are easy to use and meet operational environment requirements of mine sites, the rental market and other industries.
- ☑ Economical size design of unit can reduce transportation costs.
- ☑ Double hanger structure of the machine can guarantee the lifting center without affecting operation and maintenance space.



CONTROL PANEL

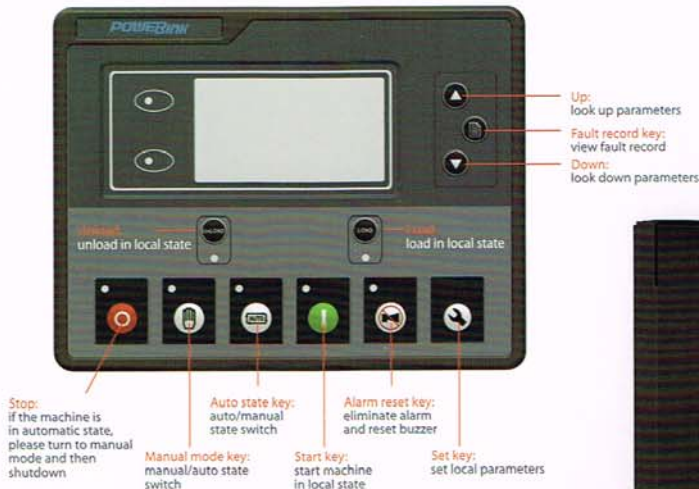

Function Keys of Control Panel



LED Display of Control Panel



Important Information Shown on the Screen

- Compressor state: wait-preheat-auto-loading-no loading-loading finished-cooling and shutdown
- Running time
- Engine speed
- Air-oil tank pressure
- Discharge pressure
- Engine oil pressure
- Fuel level
- Coolant temperature
- Coolant level
- Air inlet temperature
- Ambient temperature
- Battery voltage
- All the contents shown on CANBUS J1939: fuel pressure, fuel consumption, engine load

Language

At least six languages can be set through software PLC-3000, which are as follows: English, French, German, Italian, Spanish, Chinese

Rate of flow: 60-165cfm

Pressure: 8-13bar

STATIONARY/PORTABLE AIR COMPRESSOR



- ☑ World-renowned KUBOTA and POWERLINK engines characterized by compact structure, long service life, super silence and ultra-low emission;
- ☑ Compact structure, easy movement, low transportation cost;
- ☑ Hatchback design ensures more space for repair and maintenance;
- ☑ The base is equipped with dragging and pulling functional parts, which are easy to use and meet operational environment requirements of mine sites, the rental market and other industries;
- ☑ Extension oil flow track is installed in the barrel for the purpose of ensuring below a 2ppm gas-oil separation rate to guarantee exhaust quality;
- ☑ Height-adjustable goose neck design is equipped with rotatable outriggers in which height can also be easily adjusted, which is applicable to outdoor works under various conditions;
- ☑ The running speed of road standard compressors reaches 80KM/H, while that of off-road standard ones is less than 20KM/H.

DR Series 120-165CFM 8-13Bar

Model	Airflow Rate		Rated Power		Engine			Fuel Tank Capacity [L]	Dimension & Weight (Stationary-type)		Dimension & Weight* (Portable-type)		Road Standard**
	cu.ft/min	m ³ /min	psig	bar	Brand	Model	Power (kW)		L×W×H	kg	L×W×H	kg	
DR120-10	127	3.6	145	10.0	PowerLink	4D2.3A-C41	30	75	2100x1100x1050	1000	3870x1565x1470	1300	○
DR165-8	170	4.8	116	8.0	PowerLink	4D2.7A-C54	40	75	2100x1100x1050	1100	3870x1565x1470	1400	○
DR165-10	163	4.6	145	10.0	PowerLink	4D2.7A-C54	40	75	2100x1100x1050	1100	3870x1565x1470	1400	○

DS Series 60-165CFM 8-13Bar

DS60-8	63	1.8	116	8.0	Kubota	D722-E3B	15	30	1560x760x850	520	2785x1315x1322	700	STD
DS60-10	60	1.7	145	10.0	Kubota	D722-E3B	15	30	1560x760x850	520	2785x1315x1322	700	STD
DS80-7	81	2.3	102	7.0	Kubota	D1105-T-E3B	25	75	2130x1100x1050	1000	3870x1565x1470	1200	○
DS120-8	120	3.4	116	8.0	Kubota	D1105-T-E3B	25	75	2130x1100x1050	1000	3870x1565x1470	1200	○
DS120-10	110	3.1	145	10.0	Kubota	D1105-T-E3B	25	75	2130x1100x1050	1000	3870x1565x1470	1200	○
DS150-8	155	4.4	116	8.0	Kubota	V1505-T-E3B	33	75	2130x1100x1050	1050	3870x1565x1470	1300	○
DS150-10	147	4.2	145	10.0	Kubota	V1505-T-E3B	33	75	2130x1100x1050	1050	3870x1565x1470	1300	○
DS150-13	152	4.3	189	13.0	Kubota	V2403-M-T-E3B	44	75	2130x1100x1050	1100	3870x1565x1470	1400	○
DS165-10	177	5.0	145	10.0	Kubota	V2403-M-T-E3B	44	75	2130x1100x1050	1100	3870x1565x1470	1400	○

STD: Standard ○: Optional ×: Impossible

* : The dimensions are based on off-standard compressors with running speed of less than or equal to 20km/h; for your purchase of road standard ones, please consult PowerLink additionally.

** : The running speed of road standard compressors is less than or equal to 80km/h.

Notes:

1.The above data is based on standard operating conding as follows:1bar absolute inlet pressure,20 air inlet temperature,60% relative air humidity.

2.The pressure vessel of air compressor has obtained the standard authentication.

3.The above air compressors have been added with engine oil,engine coolant,compressor lubricating oil and a little fuel before shipment.

PORTABLE Air Compressor

Rate of flow: 165-850cfm

Pressure: 7-13bar

STATIONARY/PORTABLE AIR COMPRESSOR



- ☑ World-renowned KUBOTA, CUMMINS, PERKINS, DEUTZ and POWERLINK engines characterized by compact structure, long service life, super silence and ultra-low emission;
- ☑ One-button start, clear operational parameters, personalized operating system, intelligent control, multiple warning and shutdown protection functions.
- ☑ Gull-wing wide open door structure designed on the basis of ergonomics, together with shutter which can be removed from front and rear, ensure you the best angle and operational space during maintenance, all the daily maintenance works can be conducted at both sides of the equipment;
- ☑ The base is equipped with dragging and pulling functional parts, which are easy to use and meet operational environment requirements of mine sites, the rental market and other industries;
- ☑ Extension oil flow track is installed in the barrel for the purpose of ensuring below a 2ppm gas-oil separation rate to guarantee exhaust quality;
- ☑ Height-adjustable goose neck design is equipped with rotatable outriggers in which height can also be easily adjusted, which is applicable to outdoor works under various conditions;
- ☑ The running speed of road standard compressors reaches 80KM/H, while that of off-road standard ones is less than 20KM/H.



DR Series

165-850CFM 7-13Bar

Model	Airflow Rate		Rated Power		Engine			Fuel Tank Capacity (L)	Dimension & Weight (Stationary-type)		Dimension & Weight* (Portable-type)		Road Standard**
	cu.ft/min	m ³ /min	psig	bar	Brand	Model	Power (kW)		L×W×H	kg	L×W×H	kg	
DR165-13	177	5.0	189	13.0	PowerLink	4DT3.2C-C75	55	150	2560x1340x1710	1565	4040x1770x2330	1825	○
DR200-8	207	5.6	116	8.0	PowerLink	4DT3.2C-C75	55	150	2560x1340x1710	1565	4040x1770x2220	1825	○
DR200-10	202	5.0	145	10.0	PowerLink	4DT3.2C-C75	55	150	2560x1340x1710	1565	4040x1770x2220	1825	○
DR225-13	233	6.6	189	13.0	PowerLink	4DT4.1C-C93	68	170	2560x1340x1710	1700	4040x1770x2220	1960	○
DR285-8	288	8.1	116	8.0	PowerLink	4DT4.1C-C93	68	170	2560x1340x1710	1700	4040x1770x2220	1960	○
DR300-10	304	8.6	145	10.0	Cummins	4BTA3.9-C125	73	170	2560x1340x1710	2200	4040x1770x2220	2240	○
DR300-13	298	8.4	189	13.0	Cummins	6BTA5.9-C180	132	380	3700x1410x1850	2700	5350x2080x2220	3000	○
DR400-8	405	11.5	116	8.0	Cummins	4BTA3.9-C125	93	170	2560x1340x1710	2200	5350x2080x2220	2650	○
DR400-10	401	11.4	145	10.0	Cummins	6BTA5.9-C180	132	380	3700x1410x1850	2700	5350x2080x2320	3000	○
DR480-8	485	13.7	116	8.0	Cummins	6BTA5.9-C180	132	380	3700x1410x1850	2700	5350x2080x2320	3000	○
DR480-13	476	13.5	189	13.0	Cummins	6BTA5.9-C180	132	380	3700x1410x1850	2700	5350x2080x2320	3000	○
DR550-10	576	16.3	145	10.0	Cummins	6BTA5.9-C180	132	380	3700x1410x1850	2700	5350x2080x2320	3000	○
DR550-13	569	16.1	189	13.0	Cummins	6CTA8.3-C240	176	450	3900x1600x1850	3200	5350x2080x2220	3500	×
DR700-8	679	19.2	116	8.0	Cummins	6BTA5.9-C180	132	380	3700x1410x1850	2700	5350x2080x2320	3000	○
DR700-10	700	19.8	145	10.0	Cummins	6CTA8.3-C240	176	450	3900x1600x1850	3200	5350x2080x2220	3500	×
DR750-8	760	21.5	116	8.0	Cummins	6CTA8.3-C240	176	450	3900x1600x1850	3200	5350x2080x2220	3500	×
DR850-7	852	24.1	102	7.0	Cummins	6CTA8.3-C240	176	450	3900x1600x1850	3200	5350x2080x2220	3500	×

DS Series

200-850CFM 7-13Bar

Model	Airflow Rate		Rated Power		Engine			Fuel Tank Capacity (L)	Dimension & Weight (Stationary-type)		Dimension & Weight* (Portable-type)		Road Standard**
	cu.ft/min	m ³ /min	psig	bar	Brand	Model	Power (kW)		L×W×H	kg	L×W×H	kg	
DS200-10	214	6.1	145	10.0	Kubota	V3600-T-E3B	63	170	2560x1340x1710	1600	4040x1770x2220	1900	○
DS200-13	212	6.0	189	13.0	Kubota	V3600-T-E3B	63	170	2560x1340x1710	1600	4040x1770x2220	1900	○
DS285-8	288	8.1	116	8.0	Kubota	V3600-T-E3B	63	170	2560x1340x1710	1600	4040x1770x2220	1900	○
DS285-10	286	8.1	145	10.0	Kubota	V3600-T-E3B	63	170	2560x1340x1710	1600	4040x1770x2220	1900	○
DS285-13	284	8.0	189	13.0	Kubota	V3800DI-T-E3B	74	215	2560x1340x1710	1700	4040x1770x2220	2500	○
DS375-8	363	10.3	116	8.0	Kubota	V3800DI-T-E3B	74	215	2560x1340x1710	1700	4040x1770x2220	2500	○
DS400-8	410	11.6	116	8.0	Deutz	BF4M1013FC	105	360	2760x1340x1710	2000	4040x1770x2100	3000	○
DS400-13	410	11.6	189	13.0	Deutz	BF4M1013FC	125	360	2760x1340x1710	2000	4040x1770x2100	3000	○
DS475-10	481	13.6	145	10.0	Perkins	1106D-E66TA	130	360	3700x1410x1850	3100	5350x2080x2220	3500	○
DS475-13	476	13.5	189	13.0	Perkins	1106D-E66TA	130	360	3700x1410x1850	3100	5350x2080x2220	3500	○
DS550-8	540	15.3	116	8.0	Deutz	BF4M1013FC	125	360	2760x1340x1710	2000	4040x1770x2100	3000	○
DS550-10	540	15.3	145	10.0	Deutz	BF4M1013FC	125	360	2760x1340x1710	2000	4040x1770x2100	3000	○
DS550-13	569	16.1	189	13.0	Deutz	BF6M1013FC	169	450	3900x1600x1850	3200	5350x2080x2330	3600	×
DS700-10	700	19.8	145	10.0	Deutz	BF6M1013FC	169	450	3900x1600x1850	3200	5350x2080x2330	3600	×
DS750-8	760	21.5	116	8.0	Deutz	BF6M1013FC	169	450	3900x1600x1850	3200	5350x2080x2220	3600	×
DS850-7	852	24.1	102	7.0	Deutz	BF6M1013FC	169	450	3900x1600x1850	3200	5350x2080x2220	3600	×

STD: Standard ○: Optional ×: Impossible

* : The dimensions are based on off-standard compressors with running speed of less than or equal to 20km/h; for your purchase of road standard ones, please consult PowerLink additionally.

** : The running speed of road standard compressors is less than or equal to 80km/h.

Notes:

- 1.The above data is based on standard operating condong as follows:1bar absolute inlet pressure,20 air inlet temperature,60% relative air humidity.
- 2.The pressure vessel of air compressor has obtained the standard authentication.
- 3.The above air compressors have been added with engine oil,engine coolant,compressor lubricating oil and a little fuel before shipment.

PORTABLE Air Compressor

Rate of flow: 550-1500cfm

Pressure: 8-24bar

STATIONARY/PORTABLE AIR COMPRESSOR



- ☑ World-renowned CUMMINS, DEUTZ and CAT engines characterized by low emission, low fuel consumption and advanced electronic control;
- ☑ Directly connected by coupling, computer simulates the analysis of torsional vibration, and there is no overdrive gear in the middle, which enables it to output more air with less energy consumption;
- ☑ Spiral clash separation structure is adopted, extension oil flow track is installed in the barrel for the purpose of ensuring below a 2PPM gas-oil separation rate to guarantee exhaust quality;
- ☑ The top of air tank is equipped with specialized locking-type hinged roof skylight; it is not necessary to remove the soundproof shield or side panel during maintenance, which will speed up the efficiency of maintenance service and reduce maintenance cost;
- ☑ Four-wheel drive with large turning radius, which is applicable to outdoor works under various conditions;
- ☑ The running speed of road standard compressors is less than 20KM/H.



DR Series

850-1500CFM 8-13Bar

Model	Airflow Rate		Rated Power		Engine			Fuel Tank Capacity (L)	Dimension & Weight (Stationary-type)		Dimension & Weight* (Portable-type)		Road Standard**
	cu.ft/min	m ³ /min	psig	bar	Brand	Model	Power (kW)		L×W×H	kg	L×W×H	kg	
DR850-13	841	23.8	189	13.0	Cummins	6LTAA8.9-C360	264	780	4400x1750x2200	4400	4600x2165x2465	5100	×
DR900-10	912	25.8	145	10.0	Cummins	6LTAA8.9-C360	264	780	4400x1750x2200	4400	4600x2165x2465	5100	×
DR1050-8	1028	29.1	116	8.0	Cummins	6LTAA8.9-C360	264	780	4400x1750x2200	4400	4600x2165x2465	5100	×
DR1300-8	1293	36.6	116	8.0	Cummins	6LTAA8.9-C360	264	780	4400x1750x2200	4400	4600x2165x2465	5100	×
DR1500-8	1453	41.1	116	8.0	Cummins	QSZ500	385	780	4400x1750x2200	4800	4600x2250x2465	5600	×

550-1050CFM 17-24Bar

DR550-17	550	15.6	247	17.0	Cummins	6CTA8.3-C240	176	780	4400x1750x2200	4100	4600x2250x2465	4900	×
DR750-17	756	21.4	247	17.0	Cummins	6LTAA8.9-C360	264	780	4400x1750x2200	4400	4600x2165x2465	5100	×
DR850-17	863	24.4	247	17.0	Cummins	6LTAA8.9-C360	264	780	4400x1750x2200	4400	4600x2165x2465	5100	×
DR1050-24	1011	28.6	348	24.0	Cummins	QSZ500	385	780	4400x1750x2200	4800	4600x2250x2465	5600	×

DS Series

850-1500CFM 8-13Bar

Model	Airflow Rate		Rated Power		Engine			Fuel Tank Capacity (L)	Dimension & Weight (Stationary-type)		Dimension & Weight* (Portable-type)		Road Standard**
	cu.ft/min	m ³ /min	psig	bar	Brand	Model	Power (kW)		L×W×H	kg	L×W×H	kg	
DS850-13	841	23.8	189	13.0	CAT	C9 acert t3	224	780	4400x1750x2200	4300	4600x2165x2465	5200	×
DS900-10	912	25.8	145	10.0	CAT	C9 acert t3	224	780	4400x1750x2200	4300	4600x2165x2465	5200	×
DS1050-8	1028	29.1	116	8.0	CAT	C9 acert t3	224	780	4400x1750x2200	4300	4600x2165x2465	5200	×
DS1500-8	1453	41.1	116	8.0	CAT	C13 acert t3	328	780	4400x1750x2200	4800	4600x2165x2465	5800	×

750-1050CFM 17-24Bar

DS750-17	756	21.4	247	17.0	CAT	C9 acert t3	224	780	4400x1750x2200	4300	4600x2165x2465	5200	×
DS1050-24	1011	28.6	348	24.0	CAT	C13 acert t3	328	780	4400x1750x2200	4800	4600x2165x2465	5800	×

STD: Standard ○: Optional ×: Impossible

* : The dimensions are based on off-standard compressors with running speed of less than or equal to 20km/h; for your purchase of road standard ones, please consult PowerLink additionally.

** : The running speed of road standard compressors is less than or equal to 80km/h.

Notes:

- 1.The above data is based on standard operating conding as follows:1bar absolute inlet pressure,20 air inlet temperature,60% relative air humidity.
- 2.The pressure vessel of air compressor has obtained the standard authentication.
- 3.The above air compressors have been added with engine oil,engine coolant,compressor lubricating oil and a little fuel before shipment.



TRAILER OPTIONAL

Trailer Configuration

Trailer Type	Configuration
Road standard	Including taillight, taillight connector, taillight wiring harness and outrigger.
Off-road standard	Including reflector, rubber sealing plug, outrigger, fender, block and fixed bolt.

Mob

Goose neck type mob with adjustable traction height



Traction ring

The centroid of sing-axle trailer genset lies in the front of axle, load of towing ring is 60 ~ 120kg.



Wheel and tyre

Adopt vacuum tyre



Service braking

Road standard (SAF-AL-KO) ; Off-road standard (Yuanda)

Ground clearance

- Regarding intensive trailer, within 1m range between front and back of axle, ground clearance is larger than 100mm.
- As for discrete trailer, with respect to over 1m distance between centers of two nearby axles, 33.33mm ground clearance should be increased for each exceeded 1m.

Safety chain

Compressor Set Weight	Qty. of Safety Chain	Specification
ATM > 2.5T	1	
2.5T < ATM < 3.5T	2	
3.5 < ATM < 4.3 T	2	Diameter of the chain shall be equal or greater 7.1mm, the load of chain scission shall be equal or greater than 6.4T;
4.3 < ATM < 4.5 T	2	Diameter of the chain shall be equal or greater 9.5mm, the load of chain scission shall be equal or greater than 11.6T;



Draw bar safety chain linkage

- The chain won't link with trailer forever through hook;
- Safety chain linkage can independently bear the following external forces without causing transformation, flaw or breakage:
 - Radial drawing force—1.5x9.81xATM (N);
 - Vertical drawing force—0.5x9.81xATM (N);
 - ATM—total weight of trailer and tractor when overloading.



Parking braking

- No service braking for below 0.75T, mechanical braking for trailer from 0.75T to 3.5T;
- No hand brake for below 0.75T, as for above 0.75T, hanging and semi-hanging trailers are equipped with Parking braking and chock.
- Braking device must ensure reliable braking from up and down when trailer is on the 26% (15°) slope.
- Off-road standard trailer has no service braking.

Trafficability

- Distance between base and floor is greater than 250mm;
- The angle between axle's front and rear parts and tangent surface and floor is larger than 19°.

Sketch map of trailer

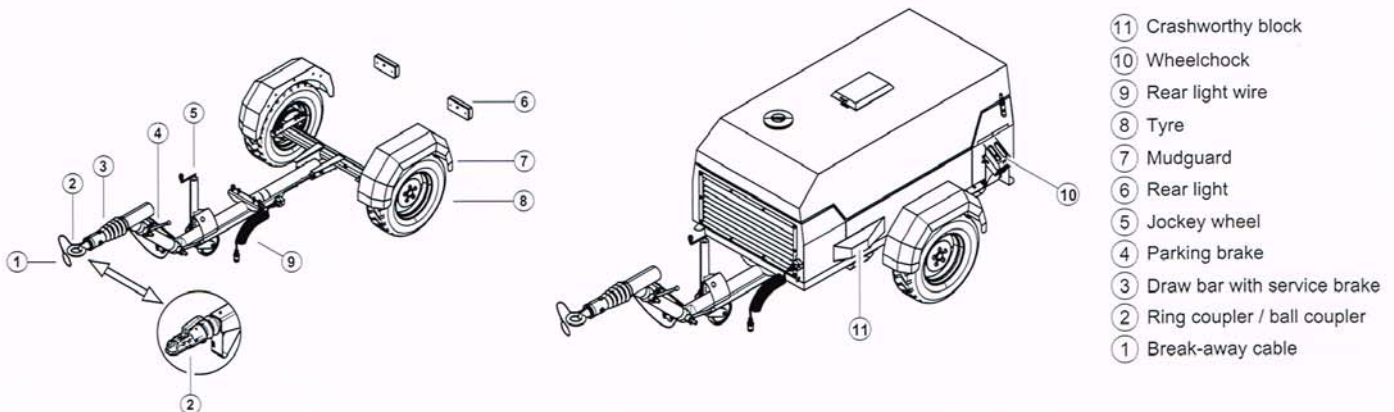

ROAD STANDARD

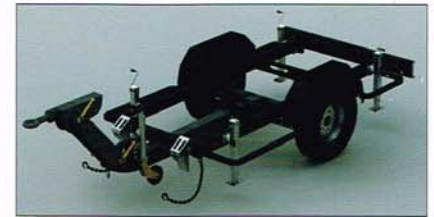
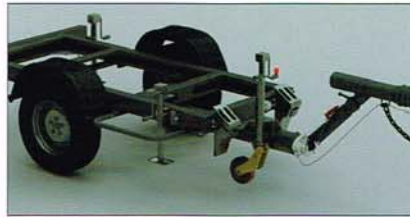

OFF-ROAD STANDARD

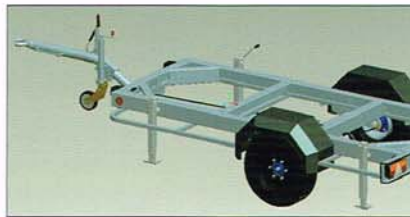
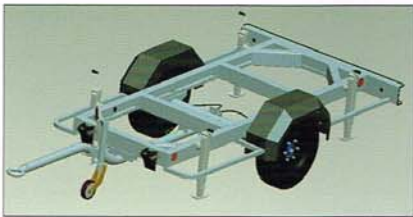

INERTIA BRAKING SYSTEM

Unique inertia brake equipment will produce pushing force on towing shaft at the joint when overcoming sensitivity limit, wheel brake is tightened by transmission equipment of operating lever.



SAFETY

- ☑ Insurance brake wire rope is linked with the main vehicle, ensuring reliable braking of trailer when accidentally unhooking.
- ☑ Service life of axle surpasses 20 years without maintenance.

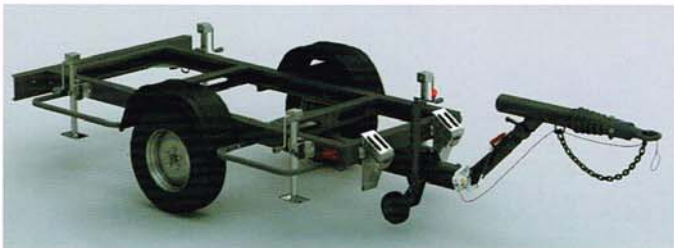

EXCELLENT ANTI-VIBRATION PERFORMANCE

When driving, the rocking arm will move up and down to press rubber stick with max deflection value of 130mm, which will make auto stable and cozy. The driving will be more steady without the clashing among metals.

